

‘

‘

<b>CONTENTS</b>	<b>page</b>
<b>1.0 DESCRIPTION</b>	<b>2</b>
Introduction .....	2
Current Dumping .....	2
Options .....	2
Variants .....	2
<b>2.0 INSTALLATION</b>	<b>3</b>
Unpacking .....	3
Contents .....	3
Mains Voltage Selection .....	3
Mains Input Connection .....	4
Earthing Requirements .....	4
Connectors .....	4
IEC Input Convention .....	4
NAB Input Convention .....	4
Neutrik Speakon Connectors .....	5
IEC Output Convention .....	5
NAB Output Convention .....	5
Output Connection Requirements .....	5
Installing Balanced Input Modules .....	6
Inrush Limiting Module .....	7
<b>3.0 OPERATION</b>	<b>7</b>
Protection .....	7
Fuses .....	7
Thermal Considerations .....	8
<b>4.0 SERVICE AND MAINTENANCE</b>	<b>8</b>
Warranty .....	8
Preventative Maintenance .....	8
Repair .....	8
Packing .....	8
Spares .....	8
<b>5.0 TECHNICAL</b>	<b>9</b>
Circuit Description .....	9
Parts List .....	9
Specification .....	9
Circuit Diagram .....	11

## 1.0 DESCRIPTION

### Introduction

The Quad 520f is a two channel power amplifier designed for professional users including broadcast, recording and public address. The power output of either channel exceeds 160W into a 4Ω load and 100W into an 8Ω load. The Quad 520f uses an implementation of the current dumping circuit technique. This circuit topology was first used on the renowned Quad 405 amplifier and resulted in the award of a Queen's Award for Technological Innovation.

The Quad 520f series is constructed in a rugged case which is designed to withstand reasonable treatment by professional users.

### Current Dumping

Current dumping involves a feed forward error correction technique and it eliminates many of the problems associated with transistor amplifiers. It is covered by patents in several countries. In a current dumping amplifier there is in effect both a low power very high quality amplifier and a high power heavy duty amplifier. The low power amplifier controls the loudspeakers at all times and it calls upon the high power amplifier to provide most of the muscle.

The small amplifier is arranged so that provided the large power transistors can deliver almost the full amount of required output current the small low power amplifier will provide the remainder accurately and completely. Therefore the output signal quality is solely dependent on the performance of the small signal amplifier and since this amplifier is only required to deliver low powers it can be made very accurate indeed.

The problems of crossover distortion, quiescent current adjustment, thermal tracking and transistor matching disappear. Current dumping amplifiers require no internal adjustments or alignment and the choice of output power transistor types is less restrictive.

### Options

The Quad 520f amplifier is available with one major option and in a few variants. The major option is the fitting of an active input balancing and isolating transformer. This is recommended where the Quad 520f is to be fed from balanced lines or where input isolation is required. The input module combines the high common mode voltage range of a conventional transformer with a truly resistive input, wide bandwidth and a low output impedance. Fitting is a simple operation and the only tool required is a screwdriver.

### Variants

The major variants of the Quad 520f are:-

The standard model (520f) is supplied with unbalanced XLR - 3 female inputs, twin lockable level controls and wired for 240/220V ac mains.

The 520M is similar to the standard 520f but has active balancing input modules fitted in the factory. The 520S slave is similar to the 520f except that it is not fitted with level controls so as to prevent the unauthorised alteration of gain.

The 521f version is made to BBC specification which includes XLR - 3 male inputs, balanced input modules, balanced level attenuators and a rear panel arrangement to allow the mains earth to be lifted from the chassis.

The 520 series can also be set for 120/110V ac operation (a simple internal change). Variants on the outline specifications above have been supplied to many clients throughout the world and Quad will be pleased to consider making variants to suit particular requirements.

## 2.0 INSTALLATION

**Unpacking** The Quad 520f amplifier is shipped in a protective polystyrene shell and packed in a heavy duty cardboard case. The packing materials should be retained for use in the unlikely event of a return for servicing being necessary.

**Contents** The packing contains the following:

**Main Unit:** One Quad 520f version amplifier.

**Accessories:** One 2m length of IEC socket terminated mains lead.  
Part No. QESOE2A.

One manual. Part No. OI528EC.

Two NL4FC cable mounting connectors to match those mounted on the chassis where fitted. Part No. PPNL4FC. (adhesive labels which indicate the wiring convention are supplied).

Shortages should be notified to the Distributor or the Factory as appropriate. Further supplies of accessories can be purchased as required.

### Mains Voltage Selection

The Quad 520f can be set internally for either 240/220V or 120/110V ac working. The change involves replacing links on the power supply board. Disconnect the power supply before making any changes.

Note that the voltage of the unit as shipped from the factory is clearly marked on the rear panel and a similar clear marking should be made if the setting is changed. Note also that the fuse rating should also be altered to suit (T6.3A for 240V ac mains and T10A for 120V ac mains). The diagram below indicates the arrangements of the linking on the printed circuit board (pcb) for the two ranges of mains input voltage.

The Quad 520f will function safely for mains voltages up to 6% of the nominal 240V ac for which performance has been characterised. The small transparent safety cover should be refitted.

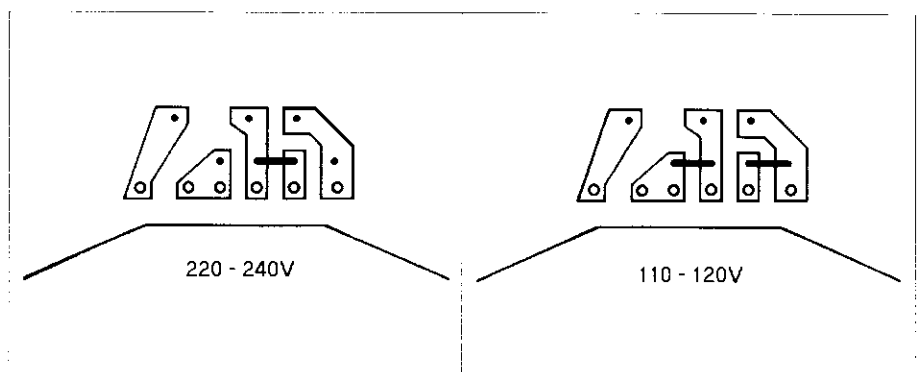

## Mains Input Connection

The mains input connection is via a standard CEE22 plug and socket. The amplifier chassis must be connected to ground via the mains supply lead. A simple retaining clip ensures that the mains connector can not be removed accidentally.

The mains lead supplied should be wired to the mains power supply plug with due regard to the following colour convention:

Brown wire	Live connection
Blue wire	Neutral connection
Green/Yellow wire	Safety earth

The Brown wire must be connected to the plug terminal marked L or coloured Red. The Blue wire must be connected to the terminal marked N or coloured Black. The Green/Yellow wire must be connected to the terminal marked E or coloured Green or Green/Yellow.

**Note:** The amplifier must be protected by a 10A fuse when a 13A plug is used, or if another type of plug is used, by a 10A fuse either in the plug or adapter, or at the distribution board. If in doubt consult a qualified electrician.

## Earthing Requirements

It is usually a safety requirement that the mains power lead earth connection is properly connected to the amplifier chassis.

### Connectors

There exists a variety of input and output connector conventions. The Quad 520f is supplied with the wiring convention for the input XLR style connector marked on the rear panel. Certain markets have standardised on the so called NAB convention. It should be noted that some manufacturers have used the alternative gender of chassis connector.

## IEC Input Convention

Chassis mounted socket (standard UK version 520f) or chassis mounted plug (521f model only).

### **Chassis Mounted Socket or Plug**

Pin 1: Chassis  
Pin 2: Hot or phase  
Pin 3: Cold or signal return

**Note:** On XLR connectors pin 1 mates before the other two pins and thus makes the safety earth first.

## NAB Input Convention

To special order.

### **Chassis Mounted Socket**

Pin 1: Cold or signal return  
Pin 2: Connected to pin 1  
Pin 3: Hot or phase

## Neutrik Speakon Connectors

Neutrik Speakon output convention for single output low voltage systems (supplied as standard for UK models).

### **Chassis Mounted Socket**

- Pin 1+: Amplifier output
- Pin 1-: Amplifier output return or 0V
- Pin 2+: Not used
- Pin 2-: Not used

## IEC Output Convention

To special order. May be either a chassis mounted plug or socket.

### **Chassis Mounted Plug or Socket**

- Pin 1: Not used
- Pin 2: Amplifier output
- Pin 3: Amplifier return or 0V

## NAB Output Convention

To special order.

### **Chassis mounted plug**

- Pin 1: Amplifier return or 0V
- Pin 2: Connected to pin 1
- Pin 3: Amplifier output

## Output Connection Requirements

The NAB convention loses the advantage of an independent safety earth connection to the input sockets. Also the sense of the output connections are reversed which could cause an amplifier output to be shorted in some systems.

The use of the Neutrik Speakon connector provides power amplifiers with a dedicated output connector which has been designed for high current loads. It obviates the problems often associated with binding posts and provides a sensible way out of the quandary of XLR genders and wiring conventions. It additionally provides a higher current rating than the XLR styles, a better cable grip and the option of solderless installation. It is currently being proposed as a standard connector to the relevant IEC bodies.

Optimum performance will only be achieved if the amplifier is correctly grounded. Each channel of the amplifier should be treated as a four terminal device and care must be taken to ensure that there is no connection between the cold sides of either output or the cold sides of an input and related output.

The diagram makes this philosophy clear.

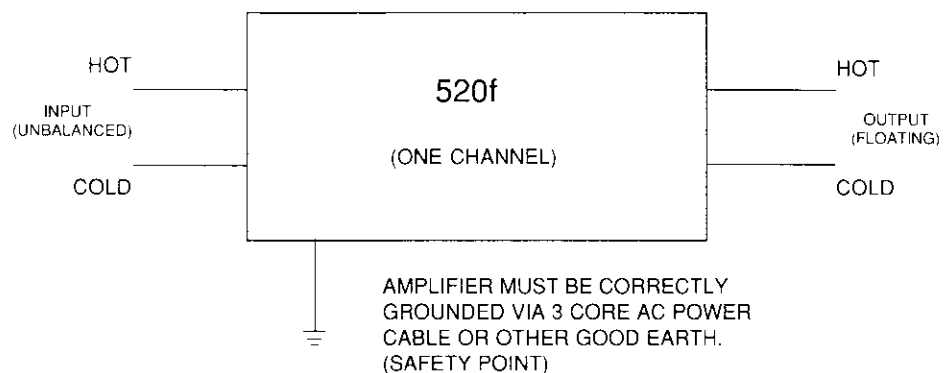

**The following points must be observed:**

- 1 The cold side of the unbalanced input must be at or close to chassis potential. An unbalanced signal source normally satisfies this requirement.
- 2 The output load must be floating and not connected to a separate ground.
- 3 Output cables which have the cold pin connected to the chassis should not be used.
- 4 The cold side of the inputs should not be connected to the cold side of the outputs.
- 5 The cold side of the two outputs should not be connected together. If a common output 0V is required (as might be required for headphones) then:
  - 5.1 Balanced or floating input modules should be fitted, one for each channel.
  - 5.2 **Also** a link wire (0.75 mm<sup>2</sup>) should be soldered between the two power supply earth eyelets on the power supply pcb. These carry orange coloured wires to the output connector on the chassis.
- 6 When balanced line input modules are fitted a chassis connection for the screen, if required, can be obtained on pin 1 of the XLR input connector on the IEC wiring convention only.

**Installing Balanced Input Modules**

The balanced input module (Quad part number Q52FINP) provides each channel with an isolated transformer input. The circuit is an active one and it takes its power from the power amplifier card which it feeds. Fitting is straightforward and only requires a Pozidrive screwdriver. Two such modules will be needed, one for each channel.

Remove the top and bottom covers which are fixed by screws on the rear panel. Each module is fixed onto the heatsink casting by the two screws which are supplied. The fixing point is a boss located above the component side of the respective amplifier pcb.

Remove the input signal leads from the amplifier pcb (the red and blue insulated wires) leaving the input cable screen attached to the amplifier pcb and attach them to the two tags of the input module. In order to maintain signal polarity the following diagram should be observed.

Take the long twin lead which is attached to the input module and plug it onto the appropriate input tags on the amplifier pcb. The two shorter individual wires (black and red) should be plugged onto the power supply tags on the amplifier card. It is important to observe the correct polarity and the red insulated wire must be connected to the positive supply and the black insulated wire to the negative supply. The module 0V supply is made through the 0V output signal connection of the module.

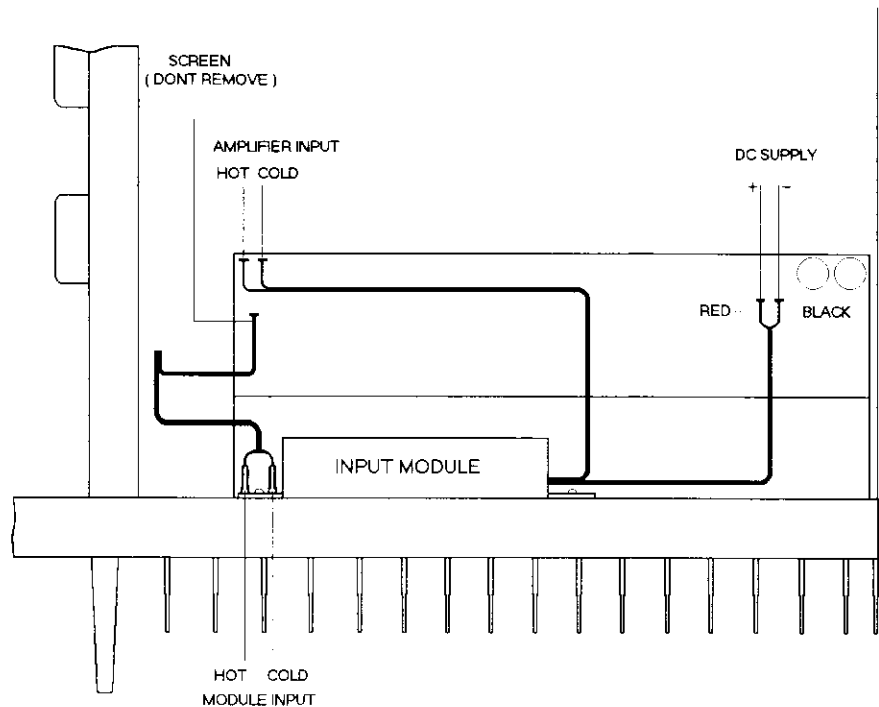

### Inrush Limiting Module

Since serial number 6500 the inrush limiter module has been fitted as standard. Its function is to control the peak current which can be taken from the mains supply when the amplifier is switched on. This protection prevents fast acting excess current trips from inappropriate activity and also causes less stress to other equipment which might be perturbed by a temporary drop in the available mains supply voltage.

### 3.0 OPERATION

The amplifier is switched on by the power switch on the front panel. The two green front panel mounted LED's should light. The gain can be adjusted by the two channel gain controls each of which is fitted with a simple tamper resistant device. Gain is a maximum when the controls are rotated fully clockwise. The 0 dBu marking represents the point where the maximum output into an 8Ω load can be obtained for a 0 dBu (0.775V rms) input level. This may be used as a convenient reference point.

### Protection

The Quad 520f series includes full protection against short circuits, input overload and inadequate ventilation. Each channel is fitted with a thermal sensor which, when a channel experiences excessive temperature for any reason, switches off that channel until the amplifier has cooled sufficiently. When the thermal trip point has been reached the front panel power LED will go out. The amplifier channel will cycle through this process until the cause of overheating is corrected or the input signal is reduced. The load is protected from damage due to component failure in the amplifier by a fuse in the power supply circuit and by the electronic centring system. This fuse is located on the power supply pcb.

### Fuses

The replacement fuse values are:

- FS1:** Mains fuse 240V ac supply 20x5 mm T6.3A
- FS1:** Mains fuse 120V ac supply 20x5 mm T10A
- FS100:** Internal protection fuse 20x5 mm T6.3A

The replacement of FS100 requires the removal of the top cover.

## **Thermal Considerations**

The Quad 520f series is designed for mounting in a nominal 483 mm (19" ) wide rack in which it occupies a 2U (89 mm) space. It can, of course, be used free standing. In either case adequate free flowing ventilation must be provided. In enclosed spaces, for example when placed in a rack with other equipment which also dissipates significant waste heat, consideration should be given to the provision of forced ventilation. It is worth noting that when, for example, both channels are fully driven into 4Ω loads for any length of time the amplifier will be asked to dissipate nearly 900W of waste heat from the output devices alone.

## **4.0 SERVICE AND MAINTENANCE**

The Quad 520f amplifier series is carefully tested and inspected at all stages of manufacture and before packing and delivery to ensure that it will provide many years of reliable service. All amplifiers are soak tested for at least 24 hours before being subjected to a second visit to the final test area. In the rare event of failure the Quad 520f series can usually be serviced in the field by replacing a complete amplifier board and heatsink assembly. This requires a pozidrive screwdriver only. No setting up or electronic alignment is required.

Replacement modules and individual components (which can be identified from the related parts list and circuit diagram) should be obtained through the vendor from whom the amplifier was purchased. It will be necessary to quote the amplifier serial number.

If the amplifier has to be returned to the vendor or directly to Quad then it should be sent in its original packing.

### **Warranty**

The Quad 520f series is guaranteed against any defect in material or workmanship for a period of twelve months from the date of purchase. Within this period the supply of replacement parts will be free of charge provided that the failure was not due to misuse, accident or negligence. Freight costs are not covered unless this has been locally agreed. Within the UK the guarantee offered with this equipment does not limit the customer's statutory rights. A guarantee card is not supplied and the guarantee period commences on the day on which the unit is delivered.

### **Preventative Maintenance**

There are no user adjustable controls within the Quad 520f series. Like any equipment of its class it will not benefit from immersion in liquids nor if it is resident in a damp environment for any appreciable time. Both operating and storage temperatures should be maintained within the range of -5°C to +45°C. The panel work may be cleaned using a moist cloth. Strong organic solvents should be avoided as they are likely to have a deleterious effect on the paint finish.

### **Repair**

Where repair is not, for a variety of reasons, a matter of simply replacing a module, reference should be made to the circuit diagram and the related parts list in order to ascertain the appropriate replacement part number. These parts will be held by and are available from Quad and its Distributors.

### **Packing**

If the amplifier is returned to Quad it is desirable that the original packing is used. The equipment will be returned in this packing where possible. Quad will charge for the use of fresh packing materials where used.

### **Spares**

Spare parts are not normally supplied as part of each amplifier. However in any particular application Quad will be pleased to consider any request to provide, for a given shipment or installation, a spares provision. The contents of this would be negotiated as required. A spares parts list is available for isolated spares requirements and parts can be requested through Quad's distributors or through Quad directly.

## 5.0 TECHNICAL

The technical details of the 520f series are given in this section.

### Circuit Description

The circuit diagram should be referred to. The detailed function of the parts of the circuit should be apparent to those aware of discrete analogue design techniques. A few guiding notes may help.

T100 and T101 provide the synthetic 0V from the power supply output.

T1, T2, T3 and their related circuitry form the input section of the amplifier and with T5, T6, T7 also performs the task of the high quality low power correction amplifier.

The output current dumpers are T9 to T12 and they drive the load through one arm of the bridge formed by C8, R29+R30, R24 and L3. DC control is provided by IC1 and the associated feedback paths. The input balancing circuitry is based around the use of L200 and IC200. A small amount of positive feedback is used to counteract the winding resistance of L200. The mains inrush current limiting circuit is based around T300. When the mains is first applied power is fed to the mains transformer via R300. This limits the current inrush. However R300 can only perform this role for a few mains cycles before it will overheat. When the mains power is applied C300 charges and eventually, via the emitter of T300, provides sufficient drive to the relay which bypasses R300 and provides the full power of the mains to the transformer.

### Parts List

For the most part the variants employ readily available components whose provenance will not normally be the cause of any great difficulty. Quad distributors hold a comprehensive parts list of all Quad products and should be able to give any necessary assistance.

### Specification

The nominal specification of the 520f series is given below, certain parameters may be affected by changes in the mains input voltage.

Power output 4 $\Omega$ : 160W per channel <0.1% THD+N at 240V, 20°C amb.

Power output 8 $\Omega$ : 105W per channel <0.1% THD+N at 240V, 20°C amb.

Power response: 10 Hz-30 kHz -3 dB ref 1kHz at 100W/8 $\Omega$

Frequency response: 20 Hz-20 kHz -0.5 dB ref 1 kHz

Group delay\*: <6  $\mu$ s at 1kHz

Group delay error\* <1.5  $\mu$ s ref 1 kHz

Distortion: <0.03% THD+N, 40 Hz any level up to 100W/8 $\Omega$   
<0.01% THD+N, 1 kHz any level up to 100W/8 $\Omega$   
<0.1% THD+N, 20 kHz any level up to 100W/8 $\Omega$

Dynamic range: -115 dB 'A' wtd ref 100w/8 $\Omega$  (15.7 kHz bandwidth)  
(hum+noise)

\*Group delay is a measure of the transit delay of signals passing through the amplifier. Group delay error is a measure of the differential delay experienced by frequency components of a complex signal passing through the amplifier.

Input sensitivity: 500 mV (-4dBu) for 160W/4Ω  
(reduced by level controls)

Input impedance: 20 kΩ unbalanced, nominal

Balanced input: 10 kΩ resistive 10 Hz - 20 kHz, nominal  
Common mode rejection >50 dB 20 Hz-20 kHz  
Common mode range 250V 50 Hz

Voltage gain: 35 dB max. Adjustable from front panel to <-90 dB

Output impedance: 0.03Ω in series with 1.5 μH

Output voltage offset: 7 mV typical

Channel separation: 95 dB at 1 kHz inputs terminated

Load stability: Unconditional any load

Power requirements: 500 VA with both channels delivering 100W/8Ω

Mains voltage: 250V-220V or 125V-110V ac  
(note lower supplies will reduce output power)

Indicators: LED (green) DC supply indication for each channel

Protection: Mains inrush; limiter fitted as standard  
Thermal; 85°C internal heatsink temperature  
Peak current; 12.5A peak output current limit  
DC offset; 0V power supply centring circuit  
DC supply fuse; T6.3A internal  
Mains fuse; T6.3A 220/240V, T10A 110/120V

Temperature range: 0°C to 45°C. High ambient requires forced ventilation for full output to be maintained

Input connector: XLR-3 chassis socket normally wired to IEC convention. Pin 1=chassis, pin 2=hot, pin 3=cold

Output connector: Neutrik NL4 wired to low output impedance convention. 1+ = signal, 1- = return, (2+ and 2- n/c)

Weight: 11 kg less packing

dimensions overall: W483 (19" rack) x H89 (2U) x D320 mm

**Graph of Max. Power Output Versus Load Impedance**

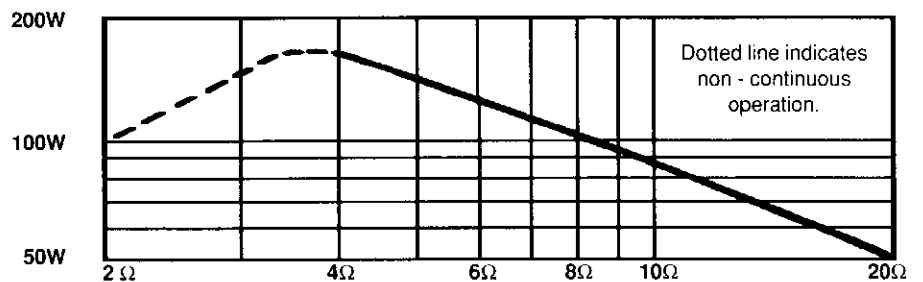

**Variants**

Variations within the Quad family is possible subject to appropriate quantities.

*The right is reserved to alter performance and specifications as required.*

INPUT ATTENUATION ARRANGMENT FOR 5211

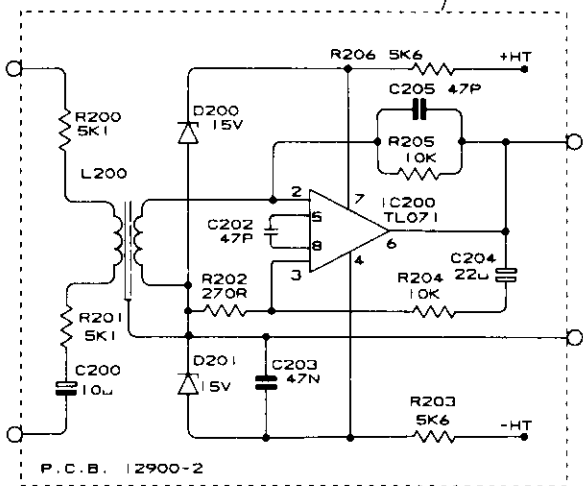
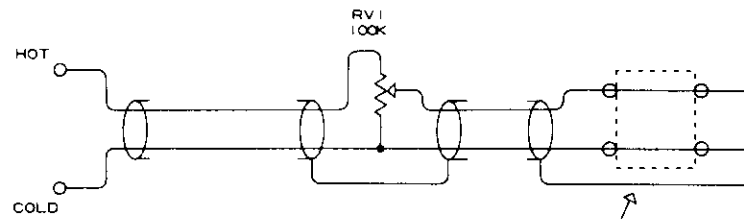
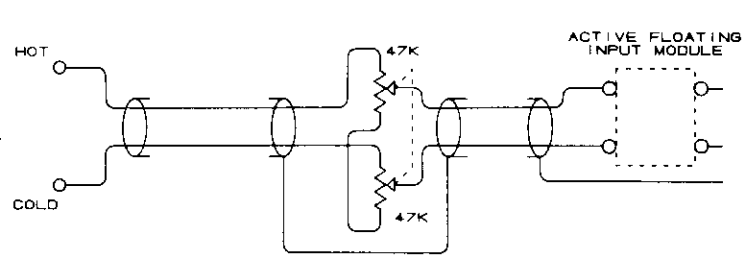

P.C.B. 12900-2

OPTIONAL ACTIVE FLOATING INPUT MODULE

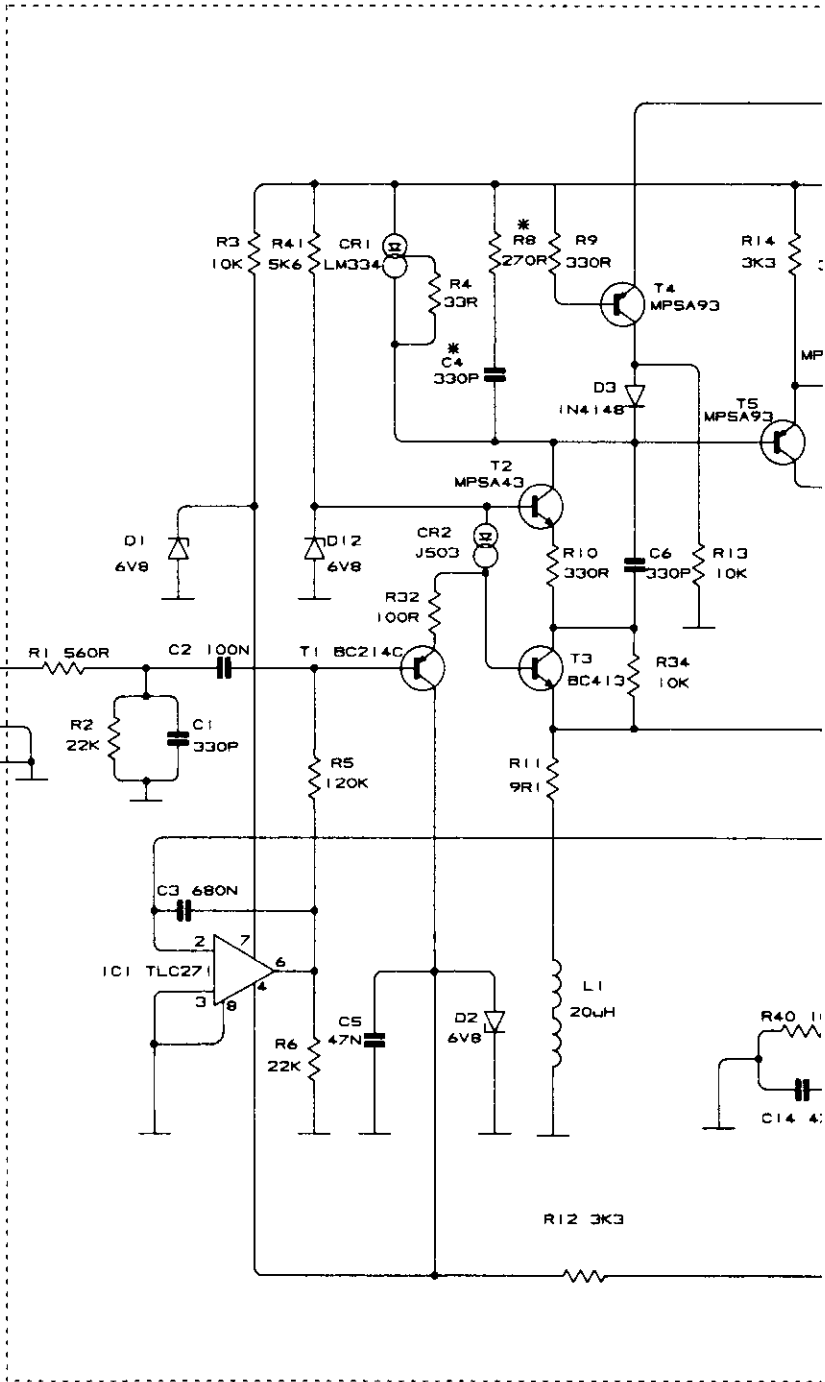

ONLY ONE CHANNEL SHOWN

17556 ALTERNATIVE - MJ15003

MPSA93 ALTERNATIVE - ZTX 542

**520f series**

**Circuit diagram 2001-6.520**  
**(pcb issue 12828-8)**

CHANNE

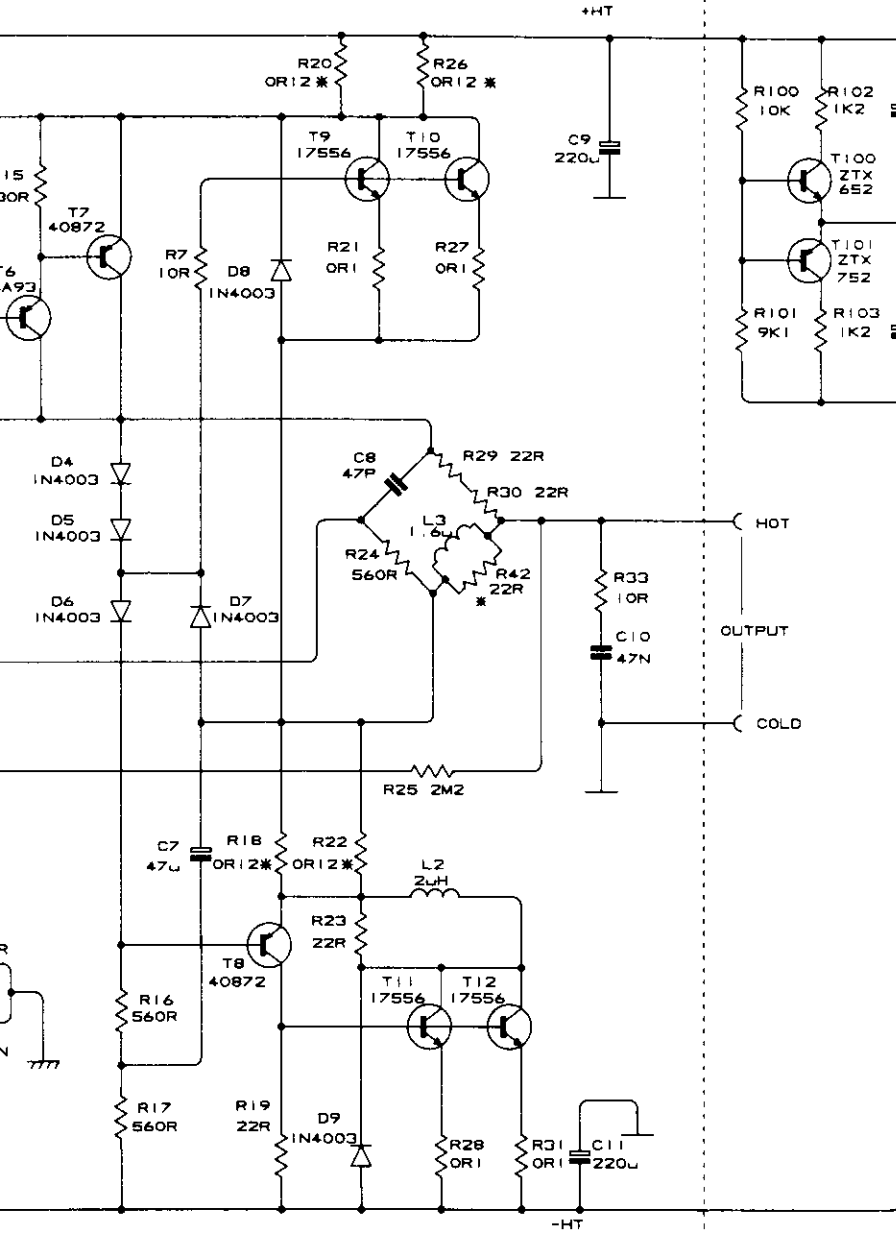

P.C.B. 12828-8

\* VALUE SUBJECT TO CHANGE

1 NOT INTERNALLY CONNECTED TO 1 OF CHANNEL 2

